

Pressure Maintaining System

for Combined Heat and Power Plant

Note_

The information provided on these pages is for guidance only. FLOWTECH accepts no responsibility for the misuse or misapplication of this information. All specifications are subject to change without notice.



Head office/Factory: 16, Namdongseo-ro 221beongil, Namdong-gu, Incheon, Korea
Tel: +82-32-715-7990 | FAX : +82-32-232-3699
Branch office : 1301-1305, 13F, Jafza view18, Jebel Ali Freezone, P.O Box 17376, Dubai, U.A.E
TEL: +971-4-885-4252 | FAX: +971-4-885-4839
www.flowtech21.co.kr

No.HWS20160401





Contents

03	History since 2005 ~
04	Need for Integrated Energy by Combined Heat and Power Generation
06	Expansion Control & Pressure Maintaining System, Supply Performance of Eco-trol
08	Characteristics of Pressure Maintaining System by Type
10	Control Panel & Operation Trends, Expertise & Patents, Other Products

History

- 2005
 - Established FLOWTECH Co., Ltd. – water hammer prevention equipment, integrated pump system and automatic fluid filtering system
 - Developed water hammer prevention controller (HAMMERtrol) and testing analysis equipment.
- 2006
 - Supplied integrated pump system (I&I WMS) to Hyundai Seongwoo Resort for the first time in Korea
 - Obtained ISO 9001 & ISO 14001 (CRK-Q0-420, CRK-E0-066)
- 2007
 - Registered a patent(1) – CES & local cooling and heating N₂ pressure expansion water controlling system (No.10-0702469)
 - Obtained a Venture certificate (No.20070200808)
 - Registered a patent(2) – Expansion water and feed water control system for parallel circulation system (No.10-0760985)
 - Registered a patent(3) – Water hammer prevention system for cooling & heating circulation piping system (No.10-0760984)
- 2008
 - Registered a patent(4) – I&I WMS integrated pump system(No.10-0795592)
 - Registered a patent(5) – pressure holding system auto control(No.10-0842818)
 - Registered a patent(6) – combined heat & power plant N₂ gas filling expansion pressure equipment (No.10-0845472)
 - Gained an INNO-BIZ certificate (No.8071-2171)
 - Registered a patent(7) – Water hammer prevention system (No.10-0868908)
- 2009
 - Registered a patent(8) – Cold Accumulator (No.10-0879629)
 - Gained a venture ethical management certificate (No.08-05), Registered the company R&D center (No.2009110132)
- 2010
 - Registered a utility model(1)– energy saving water supply line pressure pump system (No.20-0446721)
 - Registered a patent(9) – energy saving and highly reliable water hammer prevention system and operating method (No.10-0933656)
 - Registered a patent(10) – water level control method for pressure tank with multiple sensors (No.10-0982683)
- 2011
 - Registered a patent(11) – water level control method for pressure tank using level transmitter and level switch (No.10-1069126)
 - Registered a utility model(2) – energy saving water hammer prevention system (No.20-0456211)
 - Registered a patent(12) – damage sensor of bladder-type expansion tank(No.10-1077059)
 - Selected as a Quality Product Maker by Incheon City (Water hammer prevention system, pressure holding system / Nov. 2011– Jan. 2014)
 - Selected a VISION 2011 Company by Incheon City
 - Registered a patent(13) – controlling method of cooling/heating system pressure maintaining facilities with multiple sensors (No. 10-109882)
- 2012
 - Registered a patent(14) – partial pressuring device for community energy supply systems(No. 10-1142098)
 - Performance certified by Small Business Administration(No. 21-233)
 - Green Technology certified by the Ministry of Land and Maritime Affairs(No. GT-12-00090)
 - Registered a patent(15)(patent in China) – Nitrogen gas filling expansion & pressurization device(ZL 2009 8 0104325.1)
 - Designated as a supplier of excellent water hammer prevention controllers(No. 2012097)
- 2013
 - Designated as a Promising Exprot Firm by the Small & Medium Administration
 - Reported as “Engineering Industry Promotion Act”
 - Reported as “Constructino Industry”
 - Installed a Thermal Storage Tank at Combined Heat & Power Plant(Jinju)
- 2014
 - Moved to a new building in Incheon Nam-dong Industrial Park
 - CE Certification(Pressure Vessel, Air Chamber)
 - Established a branch in Dubai
 - Submitted to the Korean Intellectual Property Office (KIPO) three patent applications for valve control technologies related to water hammer reduction
 - Certified as a clean business; Risk appraisal completed
- 2015
 - KC-Certificate(KCW-2015-0027)
 - Acquire confirmation order of the surge vessel (100m³x 18units, 60m³x1unit) from Eagle Electromechanical(Contractor)for DEWA project & Award Al Riyadh Authority Project, Execute Surge Analysis project in AKOYA
- 2016
 - ASME U Certificate of Authorization
 - ASME S Certificate of Authorization

Need for Integrated Energy by Combined Heat and Power Generation

Expansion Control & Pressure Maintaining System

This expansion control and pressure Maintaining system to prevent flushing & Water Hammer of water in the 1st Thermal Piping System of Combine Heat and Power Generation or Community Cooling and Heating (CES integrated energy) Prevents Corrosion of Pipes by feeding 99.9% N₂ gas emitted from the N₂ generator in a system in the tank contacting expansion water. The system protects pipes by lowering high pressure and preventing evaporation at lower pressures in the event of sharp changes in flow of circulation piping system, sudden stop of pumps, trip caused by power failure and sudden valve closure and opening, and optimizes the system by securing reference pressure of piping system even for variable flow operation to save energy.

Why Pressure Maintaining System?

- Receives (during expansion) and returns (during cooling shrinkage) expansion water depending on changes in temperatures in cooling · heating circulation system.
- Controls makeup water
- Maintains minimum working pressure (base pressure) of the system to prevent evaporation
- No need to build bulk equipment (5m³ or higher needed- max. capacity for diaphragm type)(100m³ per unit).
- Usable even at medium and high temperatures (100°C~160°C)
- Necessary to maintain minimum pressure while working at low speeds at a variable flow system to save energy
- Prevents evaporation despite non-steady flow in pipes caused by Operation Pump trip during blackout (Surge Control)
- Basic functions for shrinkage & expansion treatment and reliable thanks to 3-stage safe operation.
- Surge Control: Prevents surge and flushing in pipes during a sudden stop of Circulation Pump (feed and return) or abrupt closure and opening of valves
- Blackout measure: base pressure in pipes maintained even during blackout
- Energy saving: 75% saved compared N₂ gas bomb
- Operation expansion: Works without thermal storage tank and heat of thermal storage tank spreads to locations higher than thermal storage tank.



Need for Integrated Energy by Combined Heat and Power Generation

Comparison with Existing Expansion Tank





Item	Existing Expansion Tank	Eco-trol System
Equipment thermal-resistant system temp	Equipment design temp:80°C(limitation of diaphragm type). System design temp:120°C	Equipment design temp:120°C(w/o diaphragm, N ₂ gas used). System design temp: 120°C
Capacity	Existing bladder type 5m ³ to the maximum (50m ³ required) 1st heat source exceeds the limit of equipment division	N ₂ gas (9.9% of N ₂ generated internally) filled Compressor/filter/freezing dryer/N ₂ gas generator Pressure container used. 100m ³ per unit
Flushing prevention	System design temp is set at 120°C, leading to possible evaporation in pipes, making circulation impossible (heating impossible and complaints expected)	Boosting is possible thanks to pipes equipped with a proper boosting device. Evaporation is preventable&enhancing safety
Expansion control	Compression and exhaust of gas(N ₂ Gas)	Expansion Tank – linked to the system Compression and exhaust of N ₂ gas
	Sol. Valve small pulse	Expansion Tank – system linkage 3-stage safety device used
Shrinkage control	Compressed air, Sol. Control	Expansion Tank – linked to the system, Mov. Control
		Expansion Tank – Separated from the system 3-stage safety device used
Measures to blackout	Unable to accept expansion Water hammer caused by pump trip during blackout makes circulation impossible due to evaporation in pipes at low pressures.	Expansion accepted : Electrical+mechanical S/B feature equipped Water hammer prevented during blackout (Tank boosting type)
Automatic control	1. Minimally functioning automatic controller	1. PLC+Touch Screen+Remote Control+HABAS Interface 2. Emergency Control (Operation during automatic control system failure)
Scalable energy saving	Unable to deal with actively	Able to deal with actively each variable flow control system of the heat load and heat source system to save energy

Certificate of Patent

Registration No.	Registration Date.	Application No.	Title of the Invention
10-2006-0103151	2007-03-27	10-0702469	Heating and Cooling System with Pressure Reduced and nitrogen Gas Charged Included Expansion Tank for High Temperature Pressure and Large System
10-2007-0135093	2008-06-26	10-0842818	Emergency Operation Method of Included Expansion Tank System
10-2007-0027574	2007-09-17	10-0760985	Expanded Water Makeup Water Control System for Pararell Circulation System
10-2007-0038720	2007-09-17	10-0760984	System for Preventing Water Hammer Of Circulation Pipeline for Cooling and Heating
10-2008-0013077	2008-08-14	10-0845472	Nitrogen Gas Filling Type Expansion and Pressurization Device
10-2010-0057649	2011-12-20	10-1098821	Control Method of Pressure Maintenance Unit for Heating and Cooling System Including a Plurality of Sensors
10-2010-0021691	2010-09-10	10-0982683	Precise and Reliable Water Level Control Method of Pressure Tank Including a Plurality of sensors
10-2010-0088217	2011-09-26	10-1069126	Water Level Control Method of Pressure Tank in Pipeline System with Level Transmitter and Level Switch
10-2010-0057647	2012-04-25	10-1142098	Pressurizing Device of Partial Area in Mass Energy System

Eco-trol Delivery and Construction site

Need for Integrated Energy by Combined Heat and Power Generation

- 
Economy An estimated **20–30% of heating costs saved annually** and higher thermal efficiency (35% for generation, 85% for both heating and cooling), compared to individual heating.
- 
Eco-friendliness **Applicable to hi-tech pollution prevention facilities** thanks to integrated facilities and **improving air environment** by reducing energy consumption.
- 
Safety Generating heat and power for the community as a whole, the method reduces **risk factors of the nation** (blackout preventable)
- 
Convenience **Uniformed indoor heating and hot water are available 24 hours a day** and more living space is available by removing boiler room from home.

Eco-trol Components

- **Filling Gas** : Compressor–Cooler–Freezing Dryer–4_Stage Filter N₂ Gas Generator–N₂ Receiver Tank–Electronic Valve– Expansion Tank
- **Expansion Control** : Pressure Sensor–Electrical Valve/1st Pressure Holding Valve, 3_Stage Manual Operation + Emergency Operation in the event of Pressure Sensor PLC failure.
- **Shrinkage Control**: Return Pump–Electrical Valve or PRV, 3_stage manual operation
- **Water-level control**: controls the optimal water level control and equipped with a device to secure min water level
- **Parallel Control**: Expansion water goes out and flows in through an adjacent piping system

References

- Combined heat and power generation or community cooling and heating (including industrial complexes and CES community cooling and heating), large-scale heat supply systems like resources recovery facilities (incinerator), etc.



Osan Combined Heat & Power Plant Expansion Project

- Project Owner : Daesung E&C Cogen Business Unit
- Contractor : Daesung E&C
- Pressure Maintaining System : 65m³ x 2 units(2nd)



Southeast District Distribution Complex CES Construction Project

- Project Owner : SH Corporation
- Contractor : Lotte E&C
- Pressure Maintaining System : 2m³ x 2 units



Jeonbuk Iksan District Heating System

- Project Owner : Jeonbuk Energy Service
- Contractor : DEAHAN Oil Pipeline Company
- Pressure Maintaining System : 60m³ x 10k x 1 unit

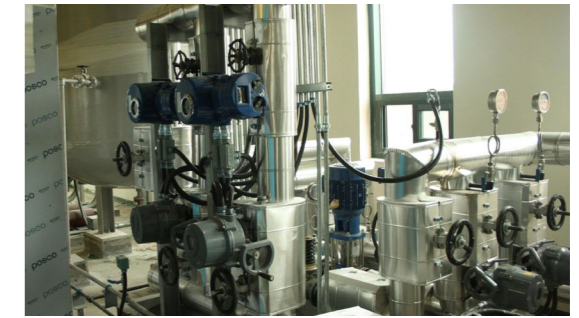

Incheon Hyangchon Heat Exchang Facility

- Project Owner : Korea Land&Housing Corporation
- Contractor : Kyungnam E&C
- Pressure Maintaining System: 12m³ x 2 units



Goyang Samsung Combined Heat & Power Plant Construction Project

- Project Owner : Korea District Heating Corporation
- Contractor : Hyundai Engineering & Construction
- Pressure Maintaining System: 90m³ x 2 units



Paju Combined Heat & Power Plant Construction Project

- Project Owner : Korea District Heating Corporation
- Contractor : Daewoo Engineering & Construction
- Pressure Maintaining System: 90m³ x 2 units



Osan Combined Heat & Power Plant Expansion Project

- Project Owner : Daesung E&C Cogen Business Unit
- Contractor : Daesung E&C
- Pressure Maintaining System : 65m³ x 1 unit (1st)



Construction of Korea Midland Power Co., Ltd.

- Project Owner : KOREA MIDLAND POWER CO., LTD.
- Contractor : Korea District Heating Engineering CO.,LTD.
- Pressure Maintaining System : 100m³ x 16kg/cm²



PanGyo Combined Heat & Power Plant Expansion Project

- Developer : Korea District Heating Corp.
- Constructor : KOLON GLOBAL
- Pressure Maintaining System : 5m³ x 25kg/cm² x 4units

Characteristics of Pressure Maintaining System by Type

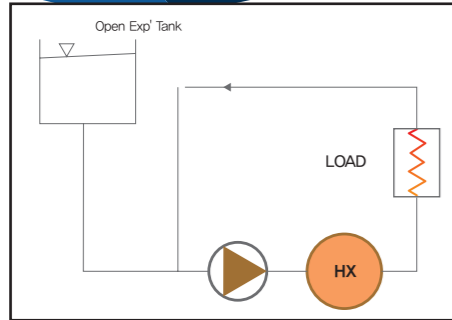

Hydrostatic Head Pressure Type

Open type elevated water tank is mounted at Circulation Pump Suction of medium-temperature hot water pipelines to pressurize

Strengths: Open type allowing for easy construction and economic advantages. Pipelines of a community heating system with thermal storage tank are of an open hydrostatic head pressure type.

Weaknesses: Problems may arise such as circulation trouble, corrosion of pipes, and heat loss. Necessary to find the site and place to install.

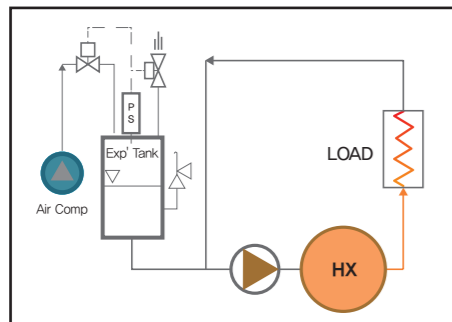

Air Boosting Pressure Tank Type

Boosting of pressure tank is made with compressed air.

Strengths: Easy to pressurize over saturated vapor pressure.

Weaknesses: Problems such as circulation trouble, corrosion of pipes may happen. Highly noisy.

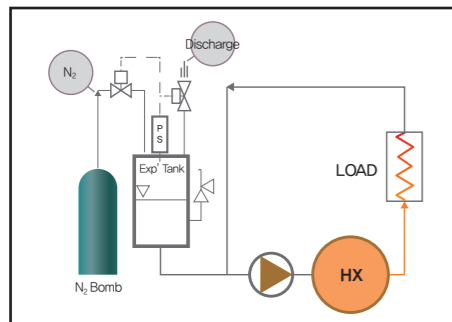

N₂ Boosting Pressure Tank Type

Pressure Tank is pressurized by N₂ gas.

Strengths: Effective to hold pressure and prevent surge. Able to handle problems such as Circulation Pump trip etc.

Equipped with less accessories and easy to maintain.

Weaknesses: Requiring high operation due to gas filling.

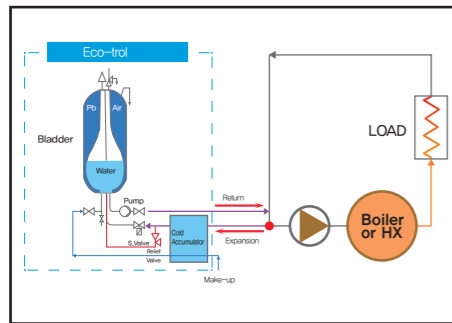

Pump Boosting Type

Once pressure falls by expansion water stored in a low pressure air-tight container, boosting by the pump starts.

Strengths: Closed piping system available. If necessary, working pressure can be changed. Low operation costs. No circulation problems and corrosion happen.

Weaknesses: Bulk capacity (5,000 liter or higher) is not available. Unable to deal with problems such as Circulation Pump trip, etc. Idle rotation of pump is highly likely due to the lack of shrinkage of Bladder once Pump starts to work.

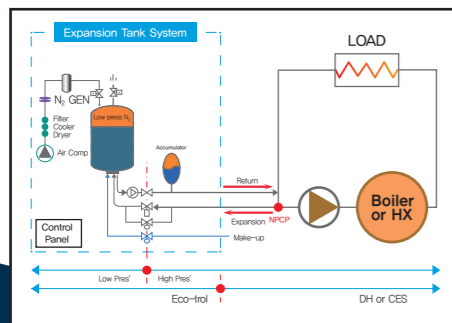

N₂ Pressure Tank & Pump Mixing Type

Pressure Tank is basically designed to prevent surge. Stored in low pressure tank and pressurized by Pump.

Strengths: Able to deal with problems such as Circulation Pump trip.

N₂ use reduced.

Weaknesses: High installation costs.

Characteristics of Pressure Maintaining System by Type

Mechanism

This system functions both as Expansion Tank and as Pressure Maintaining System to prevent flushing of water in pipes, in the 1st thermal pipe system of Combined Heat and Power Generation and Community Cooling and Heating (CES community integrated energy), and the tank contacting expansion water is filled with 99.9% N₂ gas emitted from N₂ Gas Generator in the system and remains at a low pressure to lower solubility of N₂ gas. In addition, expansion water flows in by opening both Electrical Valve (electrical) and 1st Pressure Relief Valve (mechanical) by Pressure Sensor, while Pump, Electrical Valve (electrical) and 2nd Pressure Relief Valve (Pressure Reducing Valve) are used for shrinkage (expansion water return), maintaining the system safe even during blackout.

Eco-trol System Chart and Components

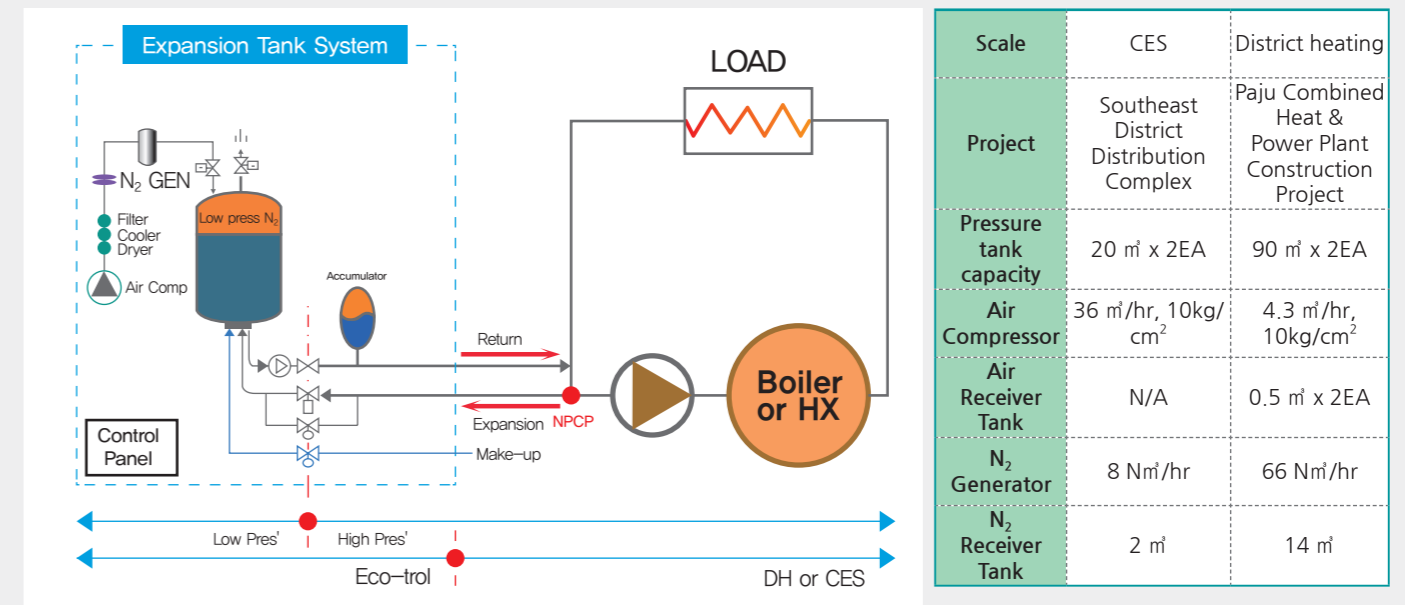

- **Filling gas:** Compressor-Cooler-Freezing Dryer-4_Stage Filter N₂ Gas Generator-N₂ Receiver Tank-Electronic Valve
- **Expansion control:** Pressure Sensor-Electrical Valve/1st Pressure Holding Valve, 3_stage manual operation+Emergency operation in the event that Pressure Sensor PLC fail.
- **Shrinkage control:** Return Pump-Electrical Valve or PRV, 3_stage manual operation
- **Water-level control:** Optimal water level control
- **Parallel control:** Expansion water is drained through an adjacent piping system

Control Panel & Operation Trends



- Equipment Name: Pressure Maintaining System
- Purpose of Equipment: Pressure Maintaining to prevent medium-temperature hot water flushing and prevent surge during the Circulation Pump trip.

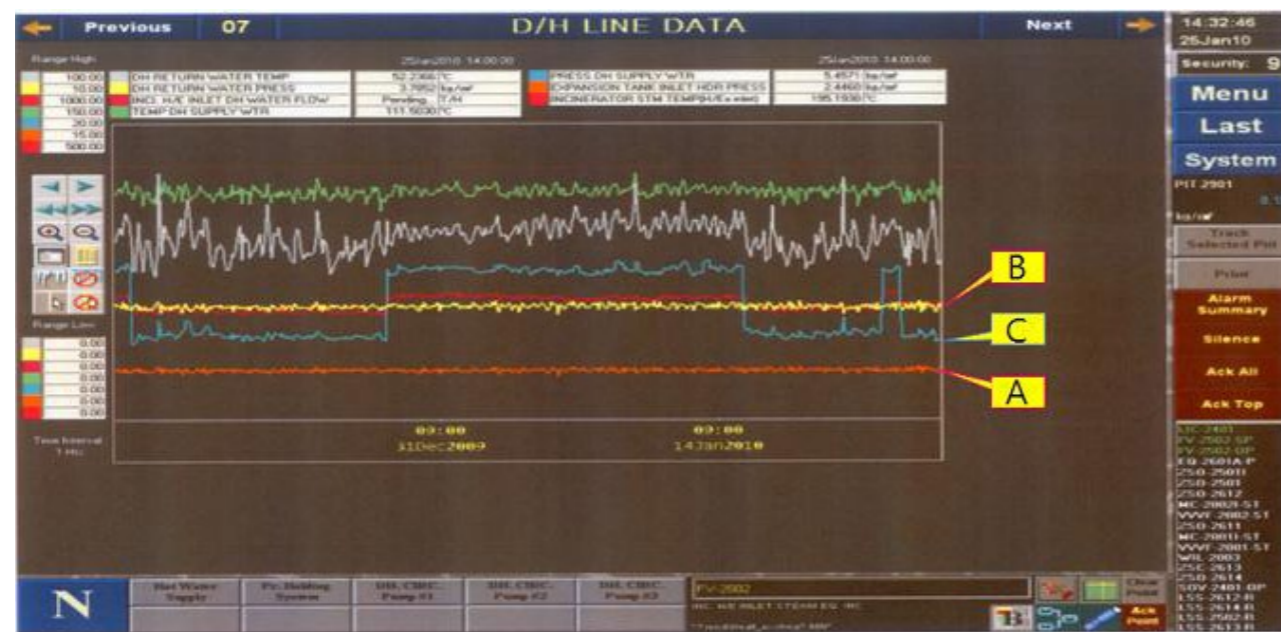

Source: Trends of Pressure Holding Data of Seongnam Resources Recovery Facility DCS (central control system)

- A. Pressure Maintaining data of Pressure Maintaining System ($2.5\text{kg/cm}^2.\text{G} \pm 0.2\text{kg/cm}^2.\text{G}$)
Pressure Maintaining System is placed 20m higher than Pump Room, and trends of suction pressure Maintaining data for Circulation Pump: **Good**
- B. Suction pressure of Circulation Pump (measured directly at DCS=pressure holding+ $2\text{kg/cm}^2.\text{G}$) target $4.5\text{kg/cm}^2.\text{G} \pm 0.2\text{kg/cm}^2.\text{G}$
A and B are the same target pressure, which varies depending on the location (height) of equipment in the piping system.
A and B follows a uniform pattern as in the picture, indicating that the data is highly reliable.
- C. Shows that supply pressure varies depending on DH supply flow, with suction pressure of Circulation Pump remaining uniform.
X axis of the data refers to Period: data for about 43 days from Nov. 13, 2009 to Jan. 25, 2010.

2014 MARMADUKE AWARD : KOMIPO Relocates an Entire Combined Cycle Power Plant

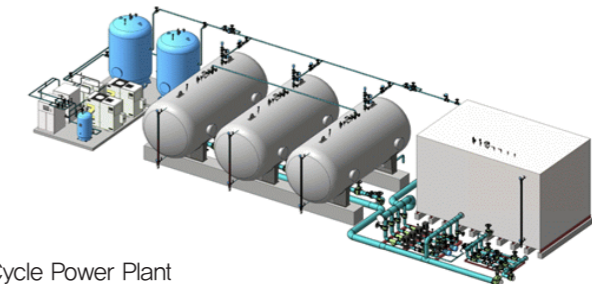

- **Project:** Korea Midland Power Co., Ltd. in No.3 Incheon, Combined Cycle Power Plant
 - **Marmaduke Award:** The Marmaduke Award, recognizes excellence in creative problem-solving that gives a power plant of any type a new life or a new role. Prior winners include an operating combined cycle plant that was moved from one multi-unit plant to another multi-unit plant, a coal-fired plant that was repowered with a circulating fluidized bed (CFB) boiler burning wood, and a district heating plant that was repowered with new, high-efficiency gas turbines. The Reinvention Award winner will be profiled in the August issue of POWER.
- FLOWTECH's Pressure Maintaining System contributed to Improvement of Efficiency**

Other Products



Fluid Network Analysis

In an effort to inspect a fluid distribution system to prevent possible massive damages by water hammer caused by sudden stop of pumps or sudden closure and opening of valves in the piping system, it is possible to select a water hammer prevention system and examine its suitability, when necessary.



Water Hammer Prevention System

As our flagship product based on a globally recognized technology, this safety system is designed to prevent water hammer where fluid pressure rises or falls by sharp changes in fluid velocity in the piping system of water supply and reuse of sewage treated water system and petrochemical plant.



Water Supply Line Pressure Pump System

Developed by FLOWTECH, this pump system solves problems of the existing system which is unable to supply water both to existing and old water reservoirs due to a sharp fall of pressure during peak hours. If supplied from water supplying system through line pressurization as before, energy is saved up to 30 ~ 40%, compared to the existing system.

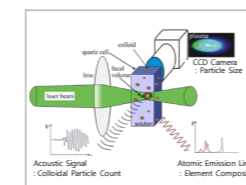

On-line Corrosion Product Monitoring System

If the power Plant using a "On-line Corrosion Product Monitoring System", the infinitesimal(ppb) concentration of iron oxide that occurs from the corrosion of power station water plumbing can be measured in real time, optimizing the water quality program for the prevention of power station steam generator container corrosion with reliability, carrying out the work with high efficiency, and there is no need for pre-treatment process of sample and injecting color developing reagent as in the previous method.



Thermal Accumulator(storage tank)

In a cogeneration plant, a Thermal Accumulator stores excessive heat during low heat load time and supplies the stored heat during high heat load time for flexible and efficient operation of heat production facilities. Also, the storage tank features quick initial stratification, minimized zone for minimized heat loss and extension of heat storage tank capacity. Besides, it has surge prevention function, reducing pipe destruction and extending the life and N2 Gas Sealing in the upper space prevents corrosion.